

PMAC625/PMAC625H

Three-phase Digital Panel Meter

Installation & Operation Manual
V2.5



ZHUHAI PILOT TECHNOLOGY CO., LTD.



Danger and warning!

- This equipment must be installed only by professionals.
- The manufacturer shall not be held responsible for failure to comply with the instruction in this manual.



Risk of electrocution, burns or explosion!

- The equipment must be installed and serviced only by qualified person.
- Prior to any work on or in the equipment, isolate the voltage inputs and auxiliary power supplies and short-circuit the secondary winding of all current transformers.
- Use the suitable voltage detection equipment to confirm the absence of voltage.
- Put all mechanisms, door and covers back in place before energizing the equipment.
- Always supply the equipment with the correct rated voltage.

Failure to take these precautions could cause serious injuries.

CONTENTS

1. Technical Specification and Parameter.....	5
2. PMAC625/PMAC625H Figure.....	8
3. PMAC625 Order Information.....	9
4. PMAC625H Order Information.....	10
5. PMAC625 Model List.....	11
6. PMAC625H Model List.....	15
7. Display and Key-press Instruction.....	16
8. Communication Protocol.....	25
9. Maintenance and Trouble Shooting.....	37
Appendix-A Terminals Definition.....	40
Appendix-B Typical Connection.....	42

General Information

PMAC625/PMAC625H three-phase digital panel meter is widely used in numerous industrial power supply places, energy sources management, automatic and intellectualized network etc.

PMAC625 series are suit for 220V/380V , 120/ 208V , 240/ 415V , 277/ 480V low voltage system, and PMAC625H series are suit for over 6KV (including 6KV) high voltage system.

The devices are designed for monitoring and displaying electric parameters include voltage, current, active power, reactive power, power factor, frequency, active energy and reactive energy. Additional, it provides two active switching inputs and two relay alarm outputs for controlling switch action. Via RS485/MODBUS communication, users may realize network management of meters.

1. Technical Specification and Parameter

Parameter	Index	
Accuracy Rate	Voltage: 0.2% Current: 0.2%, Active Power: 0.5% Active Energy: 1.0%	
Suitable Network	PMAC625: 3-phase 4-wire PMAC625H: 3-phase 4-wire or 3-phase 3-wire	
Input	Rated Current	1A or 5A (CT secondary)
	Rated Voltage	PMAC625 for low voltage system: 220/ 380V, 120/ 208V, 240/ 415V, 277/ 480V PMAC625H for high voltage system: 57.7/ 100V (PT secondary)
	Overload	Continuously: 120% of rating Instantaneous: Current 10 times / second Voltage 2 times / second.
	Frequency	35Hz ~ 65Hz
	Status Input	220Vac±25%, 220Vdc±25%
Relay Output	250VAC/5A, 30VDC/5A	
Power Supply	Wide Voltage	AC: 85V ~ 265V or DC: 80V ~ 300V
	Power Loss	< 2VA
Communication	Baudrate	Support 4800bps and 9600bps
	Protocol	Standard Modbus-RTU
Insulation Strength	2KV (testing voltage is AC valid value)	
Insulation Resistance	≥ 50MΩ	
MTBF	≥ 50000h	

Operating Environment		Operating Temperature: -10 ~ +55 Storage Temperature: -30 ~ +70 Humidity: 5% ~ 95% , non-condensing
Cut-out Dimension		89.5mm x 89.5mm (+0.5mm)
EMC	IEC 61000-4-2,Level 4	Electrostatic Discharge Immunity Test
	IEC 61000-4-3,Level 3	Radiated immunity test
	IEC 61000-4-4,Level 4	Electrical fast transient/burst immunity test
	IEC 61000-4-5,Level 4	Surge immunity test (1, 2/50 μ s ~ 8/20 μ s)
	EN 55022,Class B	Conducted emissions
	EN 55022,Class B	Radiated emissions

Parameter	LED display
Current	0.000 Unit: A The decimal point will move according to measurement value.
Voltage	00.00 Unit: V (PMAC625) 00.00 Unit: kV (PMAC625H) The decimal point will move according to measurement value.
Active power	000.0 Negative value: -00.0 Unit: kW (PMAC625) 000.0 Negative value: -00.0 Unit: MW (PMAC625H) The decimal point will move according to measurement value.
Reactive power	000.0 Negative value: -00.0 Unit: kVar (PMAC625) 000.0 Negative value: -00.0 Unit: MVar(PMAC625H) The decimal point will move according to measurement value.
Power factor	0.000 Negative value: -0.00
Frequency	00.00 Unit: Hz
Active / reactive energy	00 000 000.0 Unit: kWh or kvarh For example: the value is 12345678.9 kWh The display on LED show: 

2. PMAC625/PMAC625H Figure

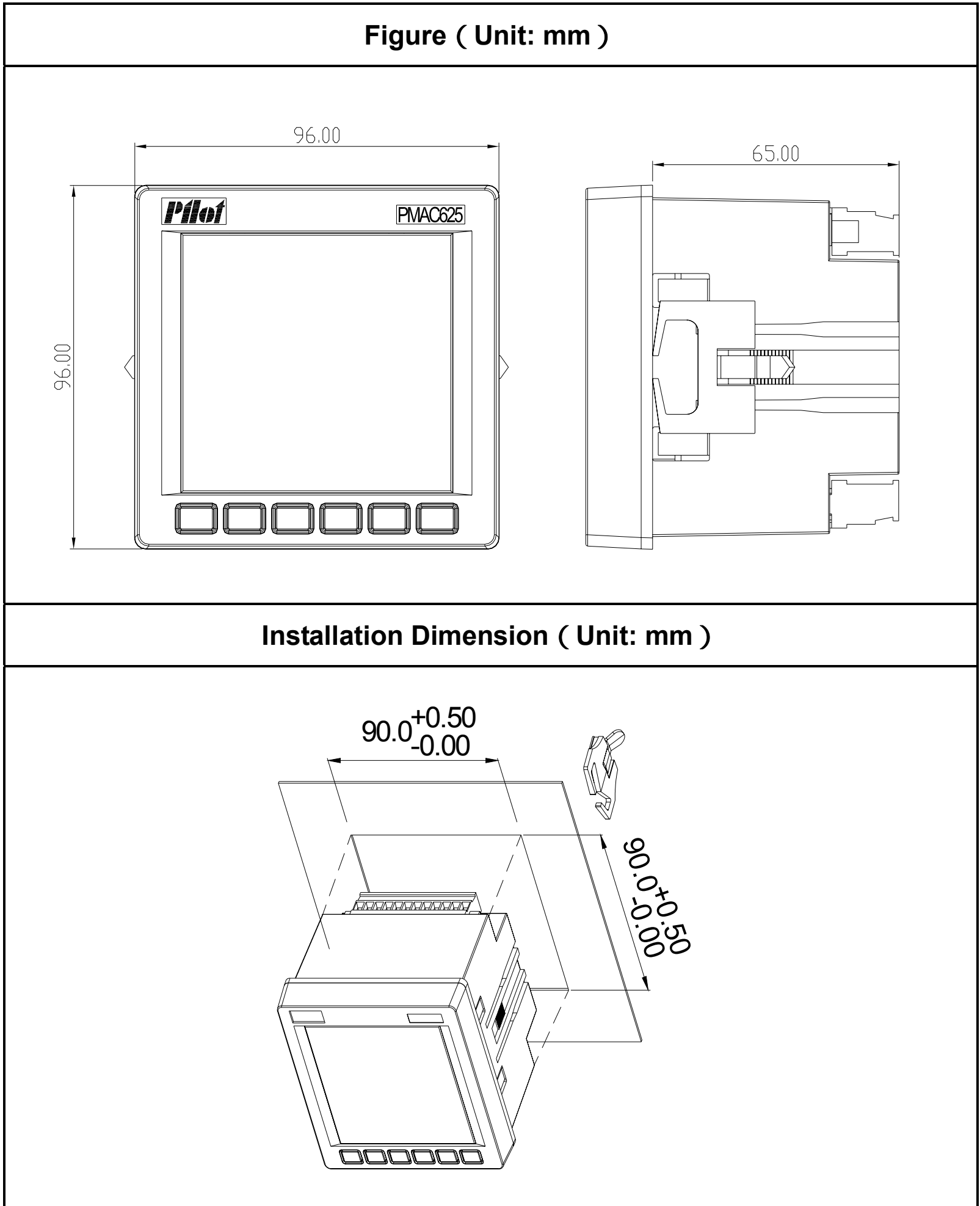

3. PMAC625 Order Information

PMAC625 - _ - _ - _	
: Module Structure	
I	Current
U	Voltage
P	Voltage + Current + Active Power
Q	Voltage + Current + Reactive Power
K	Power Factor
F	Frequency
W	Voltage + Current + Active Power + Reactive Power + Power Factor + Active Energy
Z	Voltage + Current + Active Power + Reactive Power + Power Factor + Frequency + Active Energy + Reactive Energy
: Optional Function	
A	Two 4~20mA Analog Output (this can't use with Relay Output together)
S	Two Status Input (wet contact)
R	Two Relay Alarm Output
C	One RS485 Communication
RJ	Two Relay Alarm Output, LED flash alarm.
: Rated Voltage and Current Input	
V3	220/ 380V, 5A
V4	220/380V, 1A
V5	120/208V, 5A
V6	240/ 415V, 5A

V7	277/480V, 5A
-----------	--------------

Order example: PMAC625-I-S-V3, this device measures current only, supports 2 status input, rated input 220/ 380V, 5A, for low voltage 3-phase 4-wire system.

4. PMAC625H Order Information

PMAC625H - _ - _ - _	
: Module Structure	
--	(measure all parameters: voltage, current, active power, reactive power, power factor, frequency, active energy and reactive energy)
U	Voltage
: Optional Function	
A	Two 4~20mA Analog Output (this can't use with Relay Output together)
S	Two Status Input (wet contact)
R	Two Relay Alarm Output
C	One RS485 Communication
: Rated Voltage and Current Input	
V1	57.7/ 100V, 5A
V2	57.7/ 100V, 1A

Order example: PMAC625H-U-S-V1, this devices measures voltage only, support 2 status input, rated input 57.7/100V, 5A, for 3-phase high voltage system.

5. PMAC625 Model List

Note: ② for rated input.

Product Name	Optional Function	Model
3-phase Voltage Meter		PMAC625-U
	RS485 COM	PMAC625-U-C-②
	Relay Output	PMAC625-U-R-②
	Relay Alarm Output	PMAC625-U-RJ-②
	Analog Output	PMAC625-U-A-②
	Analog Output+ RS485 COM	PMAC625-U-AC-②
	Relay Output + RS485 COM	PMAC625-U-RC-②
	Relay Alarm Output + RS485 COM	PMAC625-U-RJC-②
	Status Input + RS485 COM	PMAC625-U-SC-②
	Status Input + Analog Output	PMAC625-U-SA-②
	Status Input + Relay Output	PMAC625-U-SR-②
	Status Input + Relay Output + RS485 COM	PMAC625-U-SRC-②
	Status Input + Analog Output + RS485 COM	PMAC625-U-SAC-②
3-phase Current Meter		PMAC625-I
	RS485 COM	PMAC625- I-C-②
	Relay Output	PMAC625- I-R-②
	Relay Alarm Output	PMAC625- I-RJ-②
	Analog Output	PMAC625- I-A-②
	Analog Output+ RS485 COM	PMAC625- I-AC-②
	Relay Output + RS485 COM	PMAC625- I-RC-②
	Relay Alarm Output + RS485 COM	PMAC625- I -RJC-②
	Status Input + RS485 COM	PMAC625- I -SC-②

	Status Input + Analog Output	PMAC625- I -SA-②
	Status Input + Relay Output	PMAC625- I -SR-②
	Status Input + Relay Output + RS485 COM	PMAC625- I -SRC-②
	Status Input + Analog Output + RS485 COM	PMAC625- I -SAC-②
3-phase Active Power Meter		PMAC625-P
	RS485 COM	PMAC625-P -C-②
	Relay Output	PMAC625- P-R-②
	Relay Alarm Output	PMAC625- P-RJ-②
	Analog Output	PMAC625- P-A-②
	Analog Output+ RS485 COM	PMAC625-P -AC-②
	Relay Output + RS485 COM	PMAC625- P-RC-②
	Relay Alarm Output + RS485 COM	PMAC625- P-RJC-②
	Status Input + RS485 COM	PMAC625-P -SC-②
	Status Input + Analog Output	PMAC625-P -SA-②
	Status Input + Relay Output	PMAC625- P-SR-②
	Status Input + Relay Output + RS485 COM	PMAC625- P-SRC-②
	Status Input + Analog Output + RS485 COM	PMAC625- P-SAC-②
3-phase Reactive Power Meter		PMAC625-Q
	RS485 COM	PMAC625-Q-C-②
	Relay Output	PMAC625-Q-R-②
	Relay Alarm Output	PMAC625-Q-RJ-②
	Analog Output	PMAC625-Q-A-②

	Analog Output+ RS485 COM	PMAC625-Q-AC-②
	Relay Output + RS485 COM	PMAC625- Q-RC-②
	Relay Alarm Output + RS485 COM	PMAC625- Q-RJC-②
	Status Input + RS485 COM	PMAC625- Q-SC-②
	Status Input + Analog Output	PMAC625- Q-SA-②
	Status Input + Relay Output	PMAC625- Q-SR-②
	Status Input + Relay Output + RS485 COM	PMAC625- Q-SRC-②
	Status Input + Analog Output + RS485 COM	PMAC625- Q-SAC-②
3-phase Power Factor Meter		PMAC625-K
	RS485 COM	PMAC625-K-C-②
	Analog Output	PMAC625-K-A-②
	Analog Output+ RS485 COM	PMAC625-K-AC-②
	Status Input + RS485 COM	PMAC625-K-SC-②
	Status Input + Analog Output	PMAC625-K-SA-②
3-phase Frequency Meter		PMAC625-F
	RS485 COM	PMAC625-F-C-②
	Analog Output	PMAC625-F-A-②
	Analog Output+ RS485 COM	PMAC625-F-AC-②
	Status Input + RS485 COM	PMAC625-F-SC-②
	Status Input + Analog Output	PMAC625-F-SA-②
3-phase Active Energy Meter		PMAC625-W
	RS485 COM	PMAC625- W-C-②
	Relay Output	PMAC625- W-R-②

	Relay Alarm Output	PMAC625- W -RJ-②
	Analog Output	PMAC625- W -A-②
	Analog Output+ RS485 COM	PMAC625- W -AC-②
	Relay Output + RS485 COM	PMAC625- W -RC-②
	Relay Alarm Output + RS485 COM	PMAC625- W -RJC-②
	Status Input + RS485 COM	PMAC625- W -SC-②
	Status Input + Analog Output	PMAC625- W -SA-②
	Status Input + Relay Output	PMAC625- W-SR-②
	Status Input + Relay Output + RS485 COM	PMAC625- W-SRC-②
	Status Input + Analog Output + RS485 COM	PMAC625- W-SAC-②
3-phase Digital Integrated Meter		PMAC625-Z
	RS485 COM	PMAC625- Z -C-②
	Relay Output	PMAC625- Z -R-②
	Relay Alarm Output	PMAC625- Z -RJ-②
	Analog Output	PMAC625- Z -A-②
	Analog Output+ RS485 COM	PMAC625- Z -AC-②
	Relay Output + RS485 COM	PMAC625- Z -RC-②
	Relay Alarm Output + RS485 COM	PMAC625- Z -RJC-②
	Status Input + RS485 COM	PMAC625- Z -SC-②
	Status Input + Analog Output	PMAC625- Z -SA-②
	Status Input + Relay Output	PMAC625- Z -SR-②
	Status Input + Relay Output + RS485 COM	PMAC625- Z -SRC-②
Status Input + Analog Output + RS485 COM	PMAC625- Z -SAC-②	

6. PMAC625H Model List

Note: ② for rated input.

Product Name	Optional Function	Model
High Voltage 3-phase Voltmeter		PMAC625H-U
	RS485 COM	PMAC625H-U-C-②
	Relay Output	PMAC625H-U-R-②
	Analog Output	PMAC625H-U-A-②
	Status Input	PMAC625H-U-S-②
	Relay Output + RS485 COM	PMAC625H-U-RC-②
	Analog Output+ RS485 COM	PMAC625H-U-AC-②
	Status Input + RS485 COM	PMAC625H-U-SC-②
	Status Input + Analog Output	PMAC625H-U-SA-②
	Status Input + Relay Output	PMAC625H-U-SR-②
	Status Input + Analog Output + RS485 COM	PMAC625H-U-SAC-②
	Status Input + Relay Output + RS485 COM	PMAC625H-U-SRC-②
High Voltage 3-phase Integrated Meter		PMAC625H
	RS485 COM	PMAC625H-C-②
	Relay Output	PMAC625H-R-②
	Analog Output	PMAC625H-A-②
	Status Input	PMAC625H-S-②
	Relay Output + RS485 COM	PMAC625H-RC-②
	Analog Output+ RS485 COM	PMAC625H-AC-②
	Status Input + RS485 COM	PMAC625H-SC-②
	Status Input + Analog Output	PMAC625H-SA-②
	Status Input + Relay Output	PMAC625H-SR-②
	Status Input + Analog Output + RS485 COM	PMAC625H-SAC-②
	Status Input + Relay Output + RS485 COM	PMAC625H-SRC-②

7. Display and Key-press Instruction

Display of Real-time Measuring Data:

Indicating Characters

Real-time Data

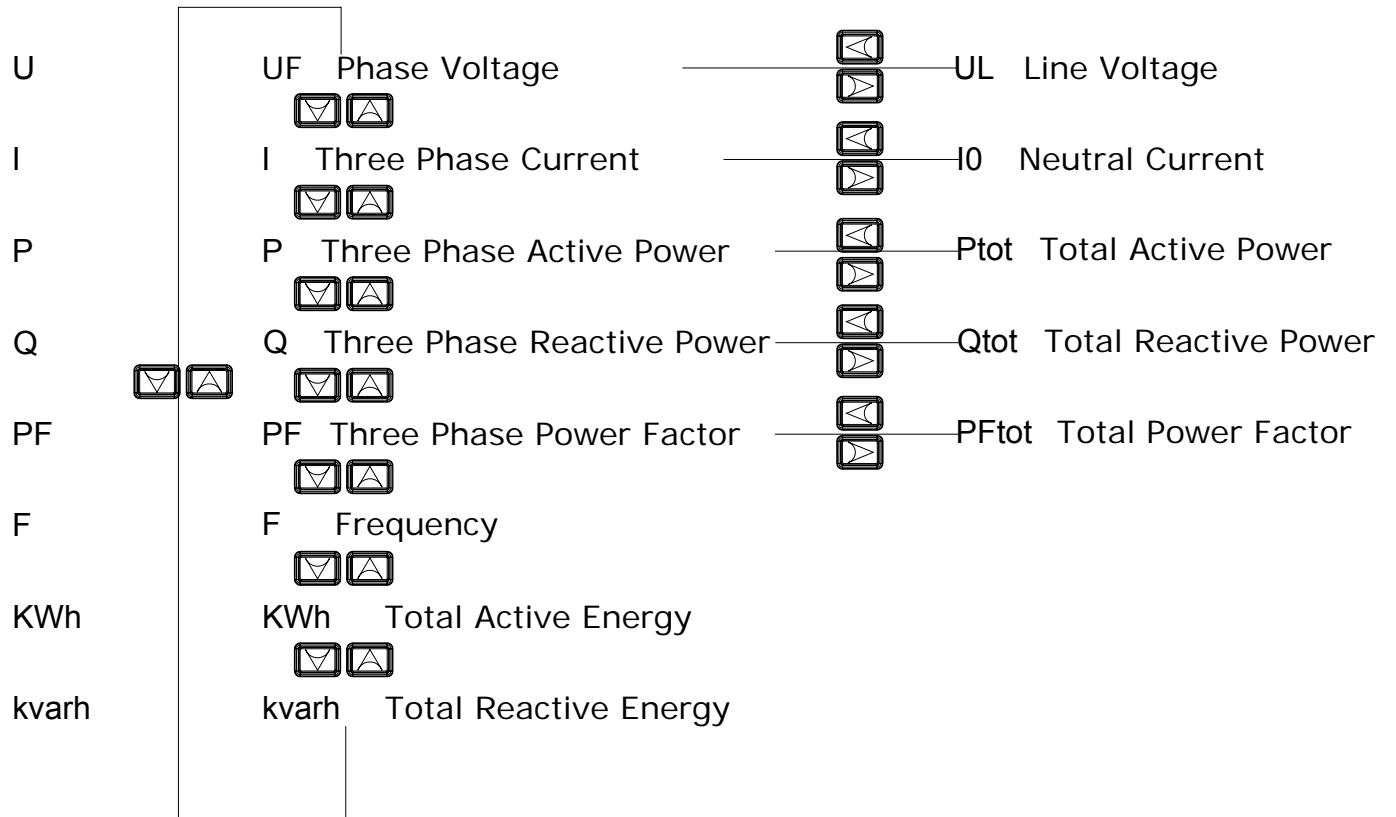

Note: Some parameters are invalid according to the model number. When model is

PMAC625-Z or PMAC625H, the meter displays all electric parameter value.

■ Display Instruction







1. The device provides 3 lines 4 digits bright LED to display electric parameters in three phase system. Default that the 1st line is value of phase A, other two lines of phase B and phase C in turn.
2. The device provides a list of indicating characters to show type of value as following:
Voltage (U), current (I), active power (P), reactive power (Q), power factor (PF), frequency (F), active energy (KWH), reactive energy (kvarh), status input 1 (S1), status input 2 (S2), communication state (COM), and programming state (FP).
When a present parameter value is displayed, the corresponding character flash.
For example, when the meter is displaying three phase current, the character (I) flash, while other (U), (P), (Q), (PF), (F), (KWH), (kvarh) constant light on.
3. When the PMAC625H is set to 3-phase 3-wire mode, the meter will not show phase voltage, neutral current, per phase active/ reactive power, per phase power factor.

■ Status Query





1. **Status Input:** It is relating to the state of status input channel. If status input channel close, the corresponding character will light on.
2. **Communication:** If the communication is normal, the character (COM) light on. If the communication error, the character (COM) flashes.
3. **Programming:** When meter is under programmed, the character (FP) light on. When quit out programming, (FP) is extinguished.

■ Key-press Function

Note: Each key-press has different function in different interface.

-  Switch submenu in same class menu. / Move cursor left.
-  Switch submenu in same class menu / Move cursor right.
-  Page down menu / Decrease value.
-  Page up menu / Increase value.
-  Enter menu / Confirm modify.
-  Enter to/ Quit the programming.

■ Measurement Data Query

1. When meter displays certain type of measurement data, the corresponding characters will flash, meanwhile, LED displays the real-time data.
2. When the meter support multiple measurements, users can press key  or  to switch interface up or down.
3. When users want to check certain real-time data, press key  or  to switch other data in the same class menu. For example, in voltage measuring mode, users can switch phase voltage data to line voltage data (initial data is phase voltage)
4. Below is the typical data display:

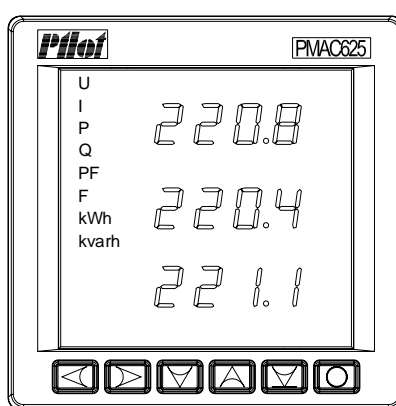

According to indicating character and LED, users can read the three phase voltage data easily. When the measurement data exceeds the maximum value (9999), a sign “OVER” will appear. When the value exceed (-999), a sign “-OVER” will appear.

■ Meter Programming

All possible programming are listed as follows but there is different in meters with different measuring function. Therefore, users should refer to the real condition of the meters when they operate:

1. Setup Password: Default password is 1 and the super password is 99. Users can set the parameter after enter the correct password only.

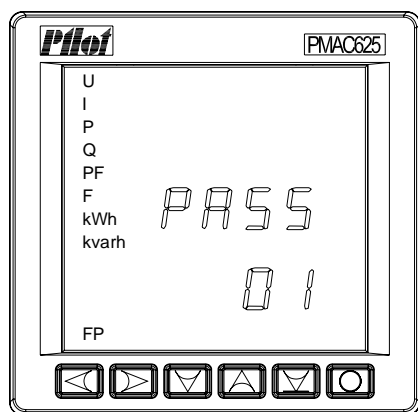

2. Measurement Mode: Low voltage meter doesn't have this option.

For high voltage meter PMAC625H, there are (3d) or (4y) for option.

4y: 3-phase 4-wire

3d: 3-phase 3-wire

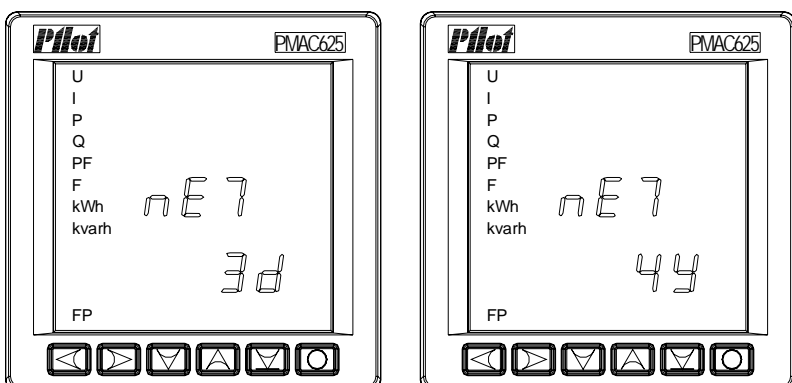

3. PT Value: Low voltage meter does not have this option.

For high voltage meter PMAC625H, it displays external PT primary value and PT secondary value.

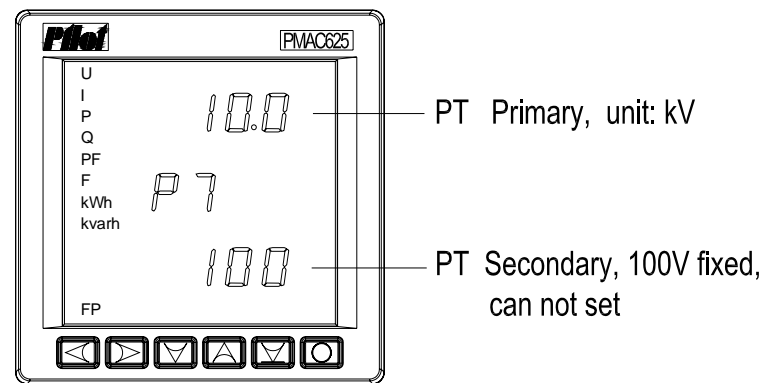

4. CT Value: External CT primary value and CT secondary value.

CT primary programmable range: 1~9999

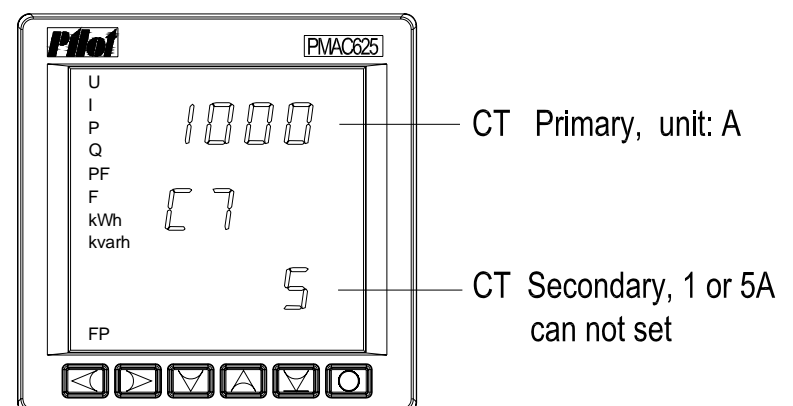

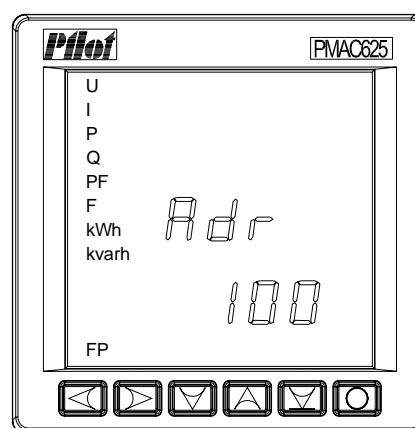

5. Communication Address:

MODBUS protocol address.

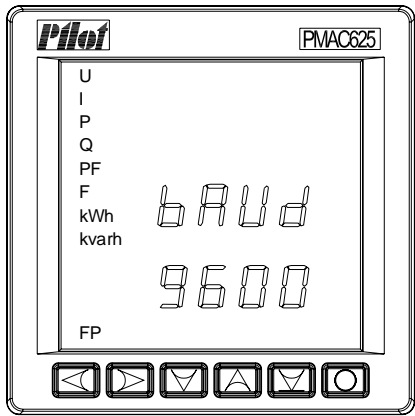

6. Baud Rate: Support 4800 and 9600bps



7. Clear Energy: Select "YES" and press key  to clear energy data.



8. Relay 1 Parameter:

Relay Mode (local and remote)

Local: Monitor and alarm automatically according to the upper or lower limit value of users' setting.

Remote: Users can control the isolator through COM port.

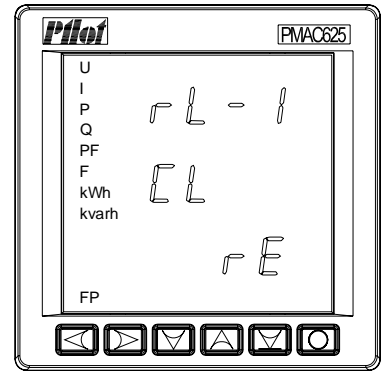
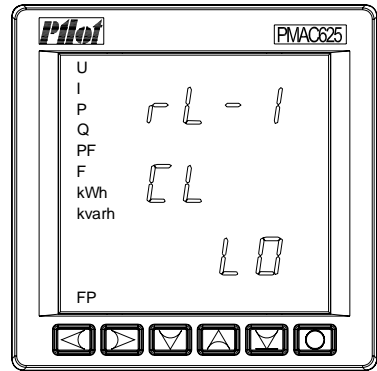

Monitoring Object of Relay: Null, phase A voltage, phase B voltage, phase C voltage, phase A current, phase B current, phase C current and neutral current.

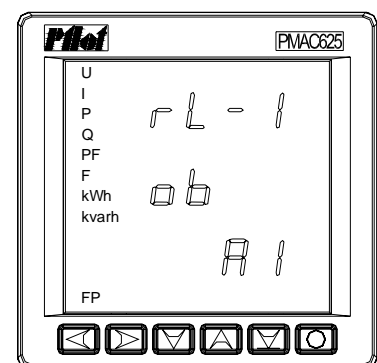
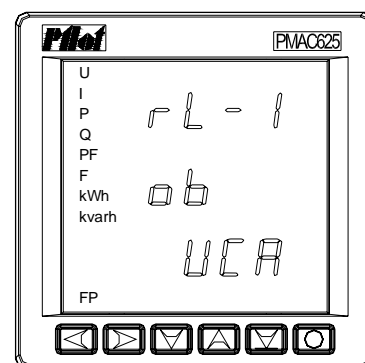
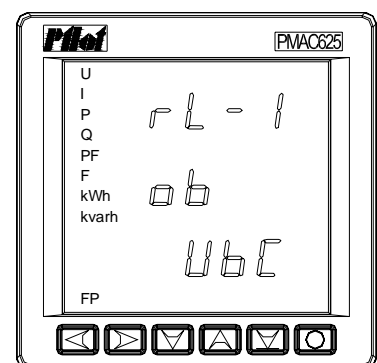
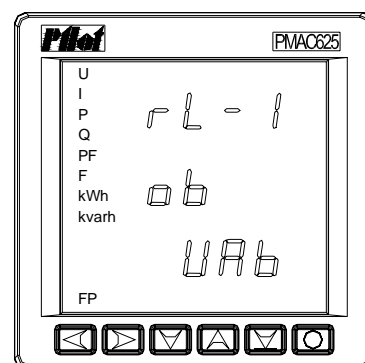
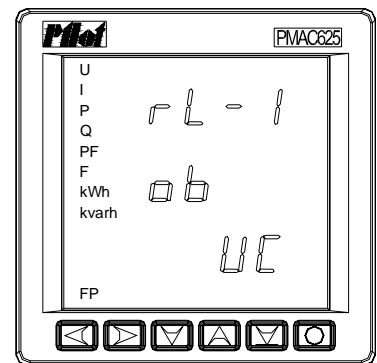
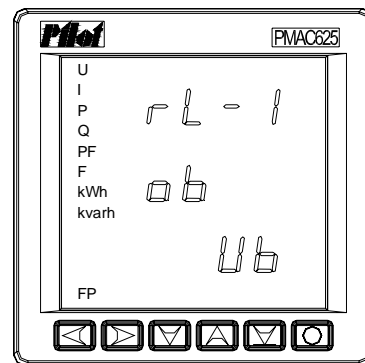
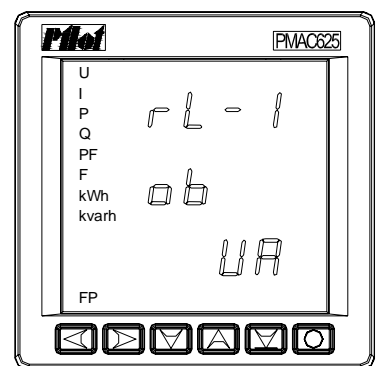
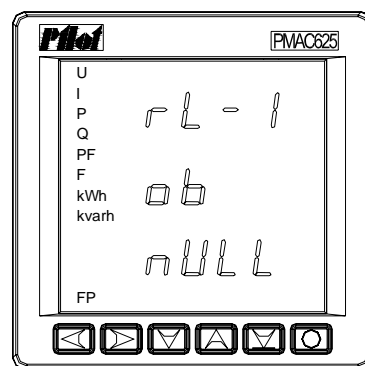

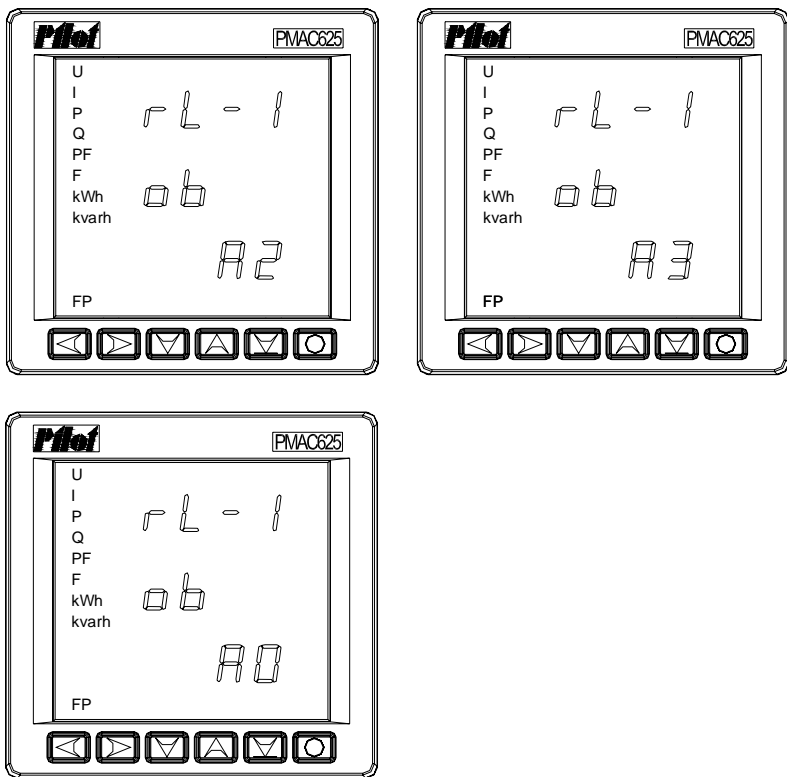

Relay Delay Time: When the relay is set in local mode, the value represents the delay time of relay. When it is in remote mode, the value represents the release time of relay. Unit is second. Maximum can be 99. If the value is 0, it means action at once, without any delay in local mode, but in remote mode, it means no release.

Relay Upper Limit: The maximum value is 120% of the rated value, and the minimum cannot be lower than 0. (the upper limit should be higher than lower limit)

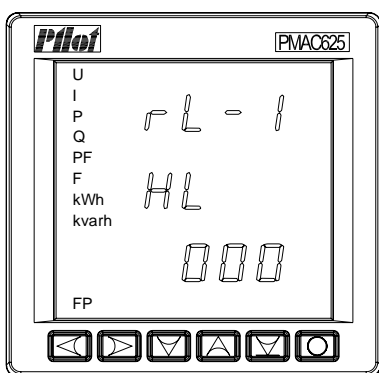
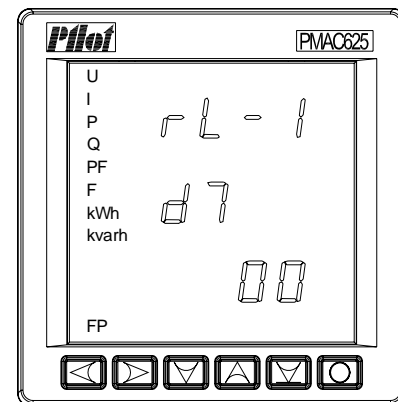

9. Relay 2 Parameter: The same as channel 1, and please refer to point 8 mentioned above.

Relay Lower Limit: The maximum value is 120% of rated value, and the minimum value cannot be lower than 0.

10. Object of Analog Output 1: Null, Ua, Ub, Uc, Uab, Ubc, Uca, Ia, Ib, Ic, In, Ptot, Qtot, Frequency, Pftot.

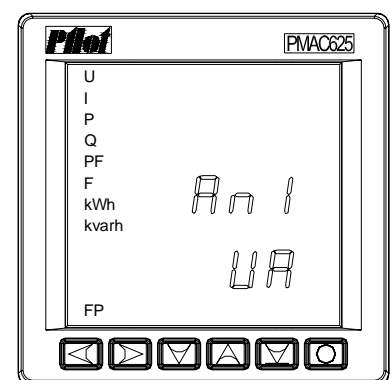
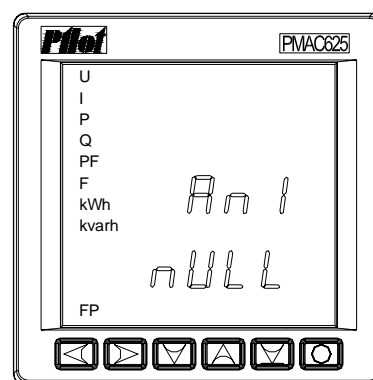
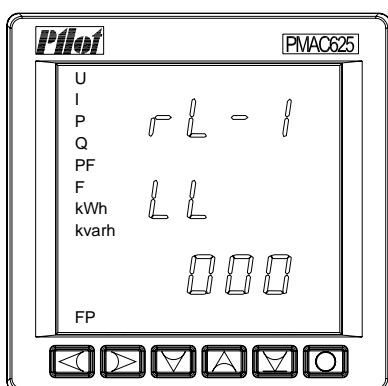

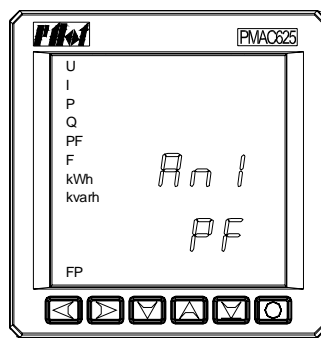
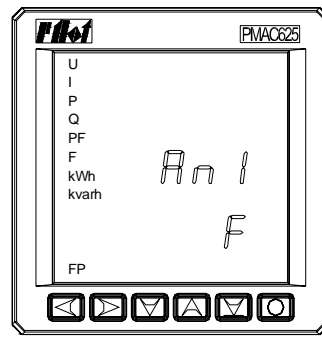
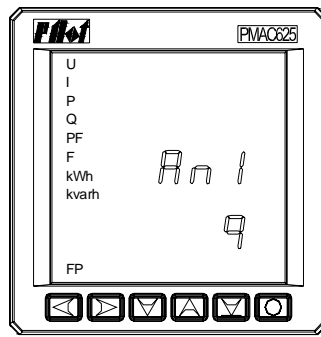
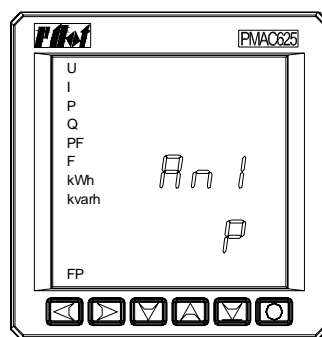
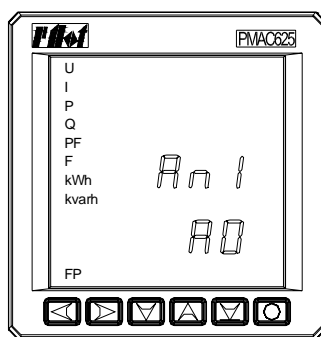
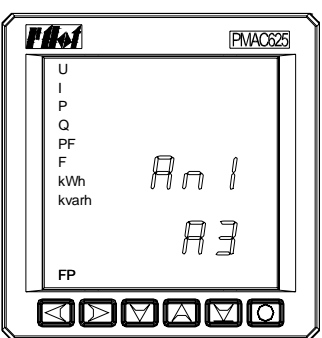
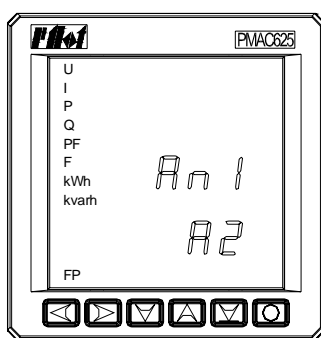
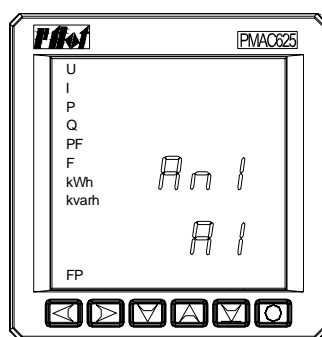
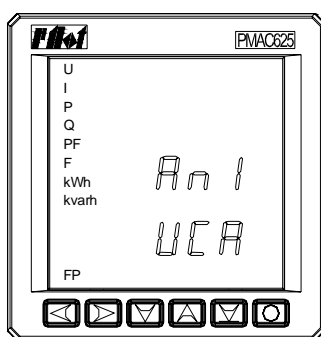
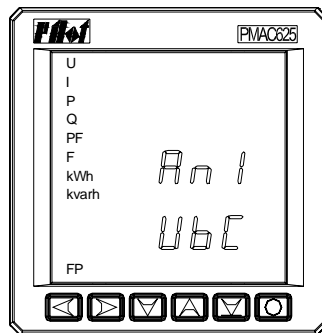
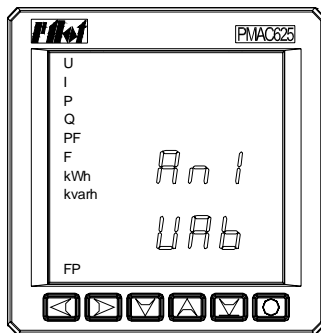
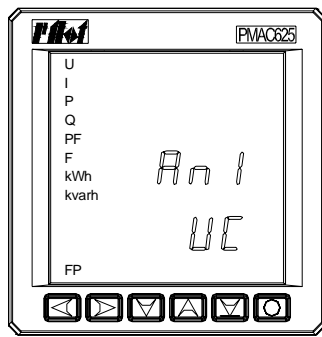

11. Object of Analog Output 2: The same as channel 1, and please refer to point 10 mentioned above.

12. Query Version NO. of Hardware

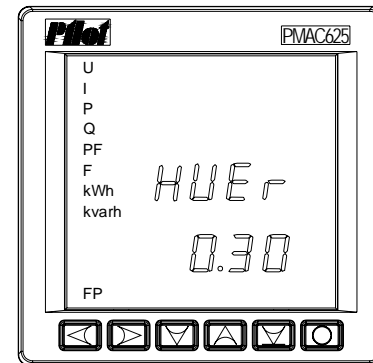

13. Query Version NO. of Software

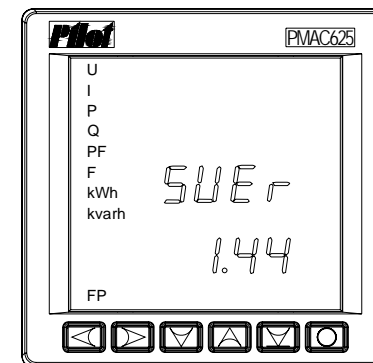

14. Demo Mode:

Select "YES" to and press  key to start Demo mode. Select "NO" and press

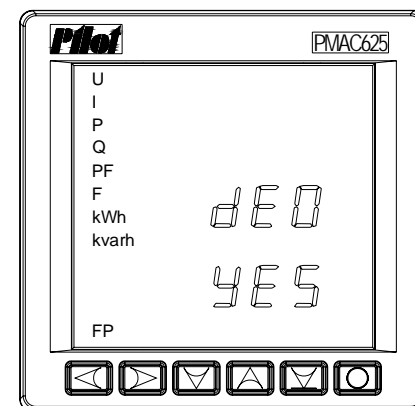

 key to stop Demo mode







■ Operation Example

Assumed rated input current of meter is 5A and the connection mode is 3-phase 4-wire, CT is 1000/5, communication address is 100 and password is 1. If users want to change CT to 2000/5, operation as follows:

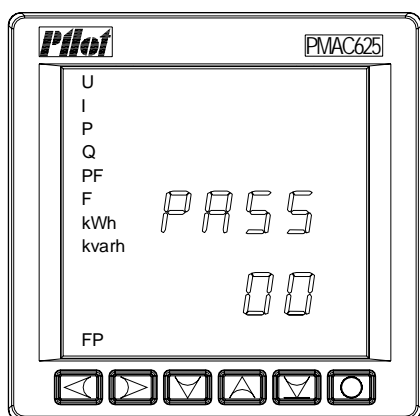

● Change CT value:

1. Press down key  quickly and release to come to programming mode, then press key  at once, the unit digit "0" will flash. It is ready for entering password, show as follows:



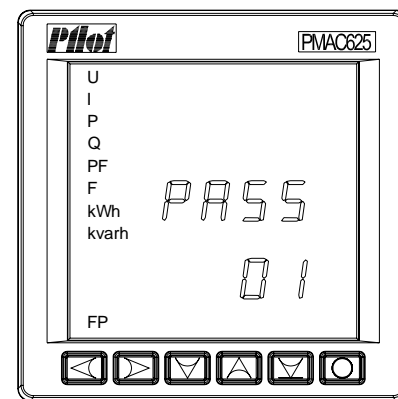



2. Press down key  or  quickly and release to increase or decrease the value, then press key  at once to confirm the value, show as follow:

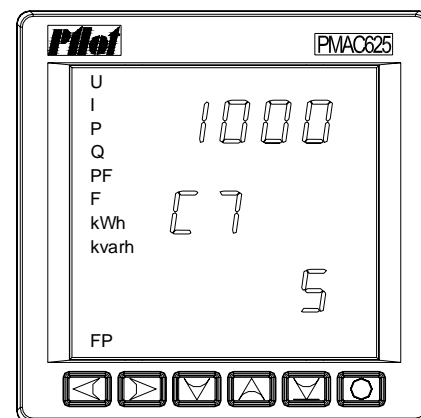

3. Press down key  or  and release to select the mode menu.
4. Select the CT menu , then press down key  and release to program the CT primary value , show as follow:



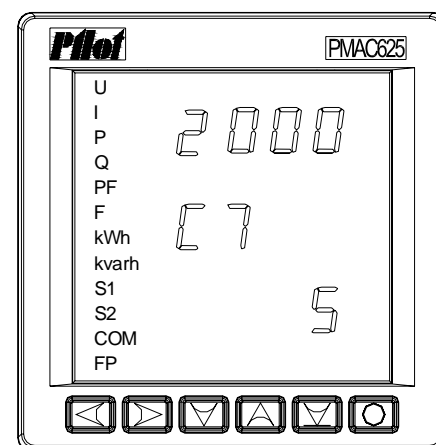

5. Press down key  or  and release to move the flashing character to the first digit.
6. Press key  or  to change the value , show as follow:



7. After change the value, press down key



at once to confirm the entering. At this moment, if operators press the key  in stead, it will quit out the programming mode and all the modification is invalid.

8. Press  to quit programming.

■ Notes

1. When input the Advance Password 99, the meter will display the initial password.
2. When the meter is operated in mode of 3-phase 3-wire, for active power, reactive power and power factor, just total values can be obtained.
3. When the CT primary value exceeds 9999, the displaying data on panel maybe incorrect. But the measurement and communication will not be affected.
4. In programming state, if the setting parameter exceeds the maximum value, the maximum value will be saved.
5. The energy value displayed on panel is the total energy of import and export.
. User can read import energy and export energy through communication.
6. There is no energy clearing menu if the meter doesn't provide energy measuring function.
7. For those meters without relay output, there is no related setting menu.
8. When the relay is set to remote, there is no setting menu for object, upper/ lower limit on the panel.
9. If setting data is invalid, meter will keep the initial data.
10. There is no description of other customized function in this manual.

8. Communication Protocol

■ Communication Rules

1. Adopts MODBUS-RTU mode.
2. Follows master-slave mode.
3. Adopts 8 data bits, 1 stop bit, without check bit.
4. The space of time between two communication frames should be more than 30ms.

■ Communication Protocol

1. It adopts standard MODBUS data format. Data frames include address information, function code, data field and check code.
2. Function code supports command 01H, 02H, 03H, 05H and 10H.
 01H: Read relay output status
 02H: Read digital input status
 03H: Read register
 05H: Relay control
 10H: Write register
3. Requested registers can't exceed 40 one time.
4. 16 bit Cyclic Redundancy Check (CRC-16) is used. And generator polynomial is $(X^{16}+X^{15}+X^2+1)$.

Register No. (Type: RO)	Description	Instruction
40001	Phase A voltage	Secondary phase voltage. Factor is 0.01. Unit is Volt. If external PT is used, the value should be multiplied by PT ratio of primary to secondary.
40002	Phase B voltage	
40003	Phase C voltage	
40004	Line AB voltage	Secondary line voltage. Factor is 0.01. Unit is Volt. If external PT is
40005	Line BC voltage	

40006	Line CA voltage	used, the value should be multiplied by PT ratio of primary to secondary.
40007	Phase A current	Secondary current. Factor is 0.001. Unit is Amp. If external CT is used, the value should be multiplied by CT ratio of primary to secondary.
40008	Phase B current	
40009	Phase C current	
40010	Neutral current	
40011 40012	Total active power	Low bit is at front, and high bit is at back. Secondary active power/ reactive power. Factor is 0.1. The highest bit is sign bit. Unit is Watt/ Var.
40013 40014	Total reactive power	If external CT and PT are used, the value should be multiplied by CT ratio and PT ratio of primary to secondary.
40015	Total power factor	Factor is 0.001. The highest bit is signs bit. Negative means logging.
40016 40017	Phase A active power Phase B active power	Secondary active power. Factor is 0.1. Unit is Watt. The highest bit is signs bit. If external CT and PT are used, the value should be multiplied by CT ratio and PT ratio of primary to secondary.
40018	Phase C active power	
		In 3-phase 4-wire mode, data is valid.

		In 3-phase 3-wire mode, data is invalid.
40019	Phase A reactive power	Secondary reactive power. Factor is 0.1. Unit is Var. The highest bit is signs bit. If external CT and PT are used, the value should be multiplied by CT ratio and PT ratio of primary to secondary. In 3-phase 4-wire mode, data is valid. In 3-phase 3-wire mode, data is invalid.
40020	Phase B reactive power	
40021	Phase C reactive power	
40022	Phase A power factor	Factor is 0.001. The highest bit is sighs bit. Negative means logging. In 3-phase 4-wire mode, data is valid. In 3-phase 3-wire mode, data is invalid.
40023	Phase B power factor	
40024	Phase C power factor	
40025	Frequency	Factor is 0.01. Unit is Hz.
40026 40027	Total active energy	Primary energy. Factor is 0.1. Unit is kWh. Low bit is at front, high bit is at back. Range of value is 0 -99,999,999.9
40028 40029	Total reactive energy	Primary energy. Factor is 0.1. Unit is kvarh. Low bit is at front, high bit is

		at back. Range of value is 0 -99,999,999.9
40030 40031	Import active energy	Primary energy. Factor is 0.1. Unit is kWh. Low bit is at front, high bit is at back. Range of value is 0 -99,999,999.9
40032 40033	Export active energy	
40034 40035	Import reactive energy	Primary energy. Factor is 0.1. Unit is kvarh. Low bit is at front, high bit is at back. Range of value is 0 -99,999,999.9
40036 40037	Export reactive energy	
40038	Status state	D0 means channel 1, D1 means channel 2. 0 means open, 1 means closed.
40039	Relay state	D0 means channel 1, D1 means channel 2. 0 means open, 1 means closed.
Register No. (Type: RW)		
Description		Instruction
40201	Communication address	Range of value: 1 ~ 247
40202	CT primary	External CT primary value, range is 1 ~ 9999
40203	Connection mode	0 means 3-phase 4-wire, 1 means 3-phase 3-wire. 0 is fixed in low voltage system. In high voltage system, 0 or 1 for

		option.
40204	PT primary	External PT primary value. Factor is 0.1. Unit is KV. In high voltage system, setting range is 1~9999. In low voltage system, it is meaningless.
40205	Null	Read-only. Meaningless fixed value for keeping registers continuous.
40206	Baud Rate	0 means 4800bps , 1 means 9600bps
40207	Object of Analog output-1	Take effect after configuration is valid. 0--no object, 1—object is Va, 2—object is Vb, 3—object is Vc, 4—object is Vab, 5—object is Vbc, 6—object is Vca, 7—object is Ia, 8—object is Ib, 9—object is Ic, 10—object is I0, 11—object is P, 12—object is Q, 13—object is F, 14—object is PF.,
40208	Object of Analog output-2	Take effect after configuration is valid. 0--no object, 1—object is Va, 2—object is Vb, 3—object is Vc,

		4—object is Vab, 5—object is Vbc, 6—object is Vca, 7—object is Ia, 8—object is Ib, 9—object is Ic, 10—object is I0, 11—object is P, 12—object is Q, 13—object is F, 14—object is PF.,
40209	Null	Read-only. Meaningless fixed value for keeping registers continuous.
40210	Null	
40211	Action mode of relay 1	Take effect after configuration is valid. 0 means local mode, 1 means remote mode.
40212	Action object of relay 1	Take effect after configuration is valid. 0--no object, 1—object is Va, 2—object is Vb, 3—object is Vc, 4—object is Vab, 5—object is Vbc, 6—object is Vca, 7—object is Ia, 8—object is Ib, 9—object is Ic, 10—object is I0
40213	Upper limit of relay 1	Take effect after configuration is valid. Percentage relation of action upper limit and rated value. Range is 0~120. Upper limit is over than lower

		limit.
40214	Lower limit of relay 1	Take effect after configuration is valid. Percentage relation of action upper limit and rated value. Range is 0~120. Lower limit is less than upper limit.
40215	Action time of relay 1	Take effect after configuration is valid. Unit is seconds, range of value: 0~99. 0 means take action at once, without any delay or automatic release.
40216	Action mode of relay 2	Take effect after configuration is valid. 0 means local mode, 1 means remote mode.
40217	Action object of relay 2	Take effect after configuration is valid. 0--no object, 1—object is Va, 2—object is Vb, 3—object is Vc, 4—object is Vab, 5—object is Vbc, 6—object is Vca, 7—object is Ia, 8—object is Ib, 9—object is Ic, 10—object is I0
40218	Upper limit of relay 2	Take effect after configuration is valid.

		Percentage relation of action upper limit and rated value. Range is 0~120. Upper limit is over than lower limit.
40219	Lower limit of relay 2	Take effect after configuration is valid. Percentage relation of action upper limit and rated value. Range is 0~120. Lower limit is less than upper limit.
40220	Action time of relay 2	Take effect after configuration is valid. Unit is seconds, range of value: 0~99. 0 means take action at once, without any delay or automatic release.
Register No. (Type: RO)	Description	Instruction
40221	Null	Read-only. Meaningless fixed value for keeping registers continuous.
Register No. (Type: RW)	Description	Instruction
40253	Clear energy	Write 78 to clear internal energy value.

Register No. (Type: RO)	Description	Instruction
40501	Software version No.	Read Only, the software version of device
40502	Hardware version No.	Read Only, the hardware version of device
40503 40504	Serial No. of device.	Read Only, the Serial No. of device

■ If device doesn't support certain measurement function, the corresponding register data is invalid.

■ Example 1 : COM address—100, the value of IB to be requested.

Request packet: 64 03 00 07 00 01 3C 3E

Response packet : 64 03 02 0C 34 F0 9B

Note: the secondary current is 3.124A, assumed CT ratio is 100, actual primary current will be 312.4 A

■ **Read the relay:**

Function code: 01H

Use 01 command to read the relay status, relay address start from 0.

The relay in response packing one bit of data for one relay. The relay status is express as 1= ON, 0 = OFF. The LSB (Least Significant Bit) of the first data byte include the output of requested address. Other relays are deduced by analogy, until to the high bit of the byte. And the following bytes are in ordered from low bit to high bit.

If the response output is not a multiple of 8, it will fill with 0 to the rest bit of last byte (until to high bit of the byte). The counting field specific the bytes of data.

Read Relay Status Format (Master → Slave)			Response Format (Slave → Master)	
Slave address	1 byte		Slave address	1 byte
Function code 01H	1 byte		Function code 01H	1 byte
Start address	2 bytes		Num. of byte (N)	1 byte
Num. of relay	2 bytes		Relay status	N byte
CRC check code	2 bytes		CRC check code	2 bytes

N= output Num./ 8, if the value ≠ 0, then N= N + 1

■ **Read the digital input status:**

Function code: 02H

Use 02 command to read the digital input status, DI address start from 0.

The DI in response packing one bit of data for one DI. The DI status is express as 1= ON, 0= OFF. The LSB (Least Significant Bit) of the first data byte include the output of requested address. Other DI is deduced by analogy, until to the high bit of the byte. And the following bytes are in ordered from low bit to high bit.

If the response output is not a multiple of 8, it will fill with 0 to the rest bit of last byte (until to high bit of the byte). The counting field specific the bytes of data.

Read DI Status Format (Master → Slave)			Response Format (Slave → Master)	
Slave address	1 byte		Slave address	1 byte
Function code 02H	1 byte		Function code 02H	1 byte
Start address	2 bytes		Num. of byte (N)	1 byte

Num. of DI	2 bytes		DI status	N byte
CRC check code	2 bytes		CRC check code	2 bytes

N= output Num./ 8, if the value ≠ 0, then N= N + 1

■ Read the register:

Function code: 03H

Master can read one or more than 1 registers. The register described Null will return 0.

Read Register Format (Master → Slave)			Response Format (Slave → Master)	
Slave address	1 byte		Slave address	1 byte
Function code 03H	1 byte		Function code 03H	1 byte
Start address	2 bytes		Num. of byte (2 × Register Num.)	1 byte
Num. of registers	2 bytes		Data of register No. 1	1 byte
CRC check code	2 bytes		Data of register No. 2	2 bytes
			...	
			CRC check code	2 bytes

■ Relay control

Function code: 05H

Under this mode, it just can control a single relay. We can read the relay status from register. In register, the relay address starts from 0. The Relay 1 address is 0, Relay 2 address is 1, and so on. Send sexadecimal FF 00 to close the relay. Send sexadecimal 00 00 to release a relay. All other value are invalid.

Control Relay Format (Master → Slave)			Response Format (Slave → Master)	
Slave address	1 byte		Slave address	1 byte
Function code 05H	1 byte		Function code 05H	1 byte
Relay address	2 bytes		Relay address	1 byte
Control command	2 bytes		Control command	2 bytes
CRC check code	2 bytes		CRC check code	2 bytes

■ Write to register

Function code: 10H

Master can write one or more than one register. The register described Null is invalid.

Read Register Format (Master → Slave)			Response Format (Slave → Master)	
Slave address	1 byte		Slave address	1 byte
Function code 10H	1 byte		Function code 10H	1 byte
Start address	2 bytes		Start address	2 bytes
Num. of registers	2 bytes		Data of register No. 1	2 bytes
Num. of byte (2 × Register Num.)	1 byte		CRC check code	2 bytes
Data of register No. 1				

Data of register No. 2	2 bytes		
...			
CRC check code	2 bytes		

9. Maintenance and Trouble Shooting

Possible problem	Possible cause	Possible solution
There is no display on device after impose power supply.	The power supply fails to be imposed on the meter.	<p>Check if the correct working voltage has been imposed on the L/+ and N/- terminals of the meter.</p> <p>Check if the fuse for the control power supply has been burnt down.</p>
The measured value is not correct or does not conform to the expectation.	The voltage measurement is not correct.	<p>Check if the neutral point has been connected reliably.</p> <p>Check if the measured voltage matches the rated parameter of the meter.</p> <p>Check if the PT ratio has been set correctly.</p>

	<p>The current measurement is not correct.</p>	<p>Check if the measured current matches the rated parameter of the meter.</p> <p>Check if the CT ratio has been set correctly.</p>
	<p>The power measurement is not correct.</p>	<p>Check if the measurement mode has been set correctly.</p> <p>Check if the phase sequence corresponding to the voltage and the current is correct.</p> <p>Check if the current terminals of the same name are wrong.</p>
<p>The digital input status no changing.</p>	<p>The voltage relating to digital input is not correct.</p>	<p>Check if the types of external nodes match the rated parameters of the meter.</p> <p>Check if the external connection is correct.</p>
<p>The relay output status no changing.</p>	<p>The relay does not receive the control command.</p>	<p>Check if the communication link is correct.</p>

	<p>The control mode of relay is not correct.</p>	<p>Check if the current relay is under the correct mode.</p>
<p>There is no communication between the upper end device and the meter.</p>	<p>The communication address of the meter is not correct.</p>	<p>Check if the address of the meter is consistent with its definition or if there are more than two identical addresses in the same network.</p>
	<p>The communication baudrate of the meter is not correct.</p>	<p>Check if the communication baudrate of the meter is consistent with its definition.</p>
	<p>The communication link has not been connected to the terminal resistor.</p>	<p>Check if the 120-Ohm resistor has been connected.</p>
	<p>The communication link suffers interference.</p>	<p>Check if the communication-shielding layer has been earthed effectively.</p>
	<p>The communication line is interrupted.</p>	<p>Check if the communication cable has been disconnected.</p>

Appendix-A Terminals Definition

No.	Definition	Instruction	No.	Definition	Instruction
1	L/+	Positive pole of power supply	2	NC	Null
3	N/-	Negative pole of power supply	4	NC	Null
5	NC	Null	6	S1	Status input 1
7	S2	Status input 2	8	SG	Status input public GND
9	RL1	Relay output 1	10	RL2	Relay output 2
11	RLG	Relay output public GND	12	RS485-	485 negative pole
13	RS485+	485 positive pole	14	SHLD	RS485 shield
15	I32	Phase C current outgoing line	16	I31	Phase C current incoming line
17	I22	Phase B current outgoing line	18	I21	Phase B current incoming line
19	I12	Phase A current outgoing line	20	I11	Phase A current incoming line
21	NC	Null	22	VN	Neutral line
23	NC	Null	24	V3	Phase C voltage
25	NC	Null	26	V2	Phase B voltage

27	NC	Null	28	V1	Phase A voltage
----	----	------	----	----	-----------------

Note: If the meter provides analog output function, the terminal No. 9, 10, 11 will be defined as below:

No.	Definition	Instruction	No.	Definition	Instruction
9	AN1	Analog output 1	10	AN2	Analog output 2
11	ANG	Relay output public GND			

Appendix-B Typical Connection

Low voltage system, measuring all parameter in 3-phase 4-wire connection mode, with status input function and one RS485 communication.

Model: PMAC625-Z-SC

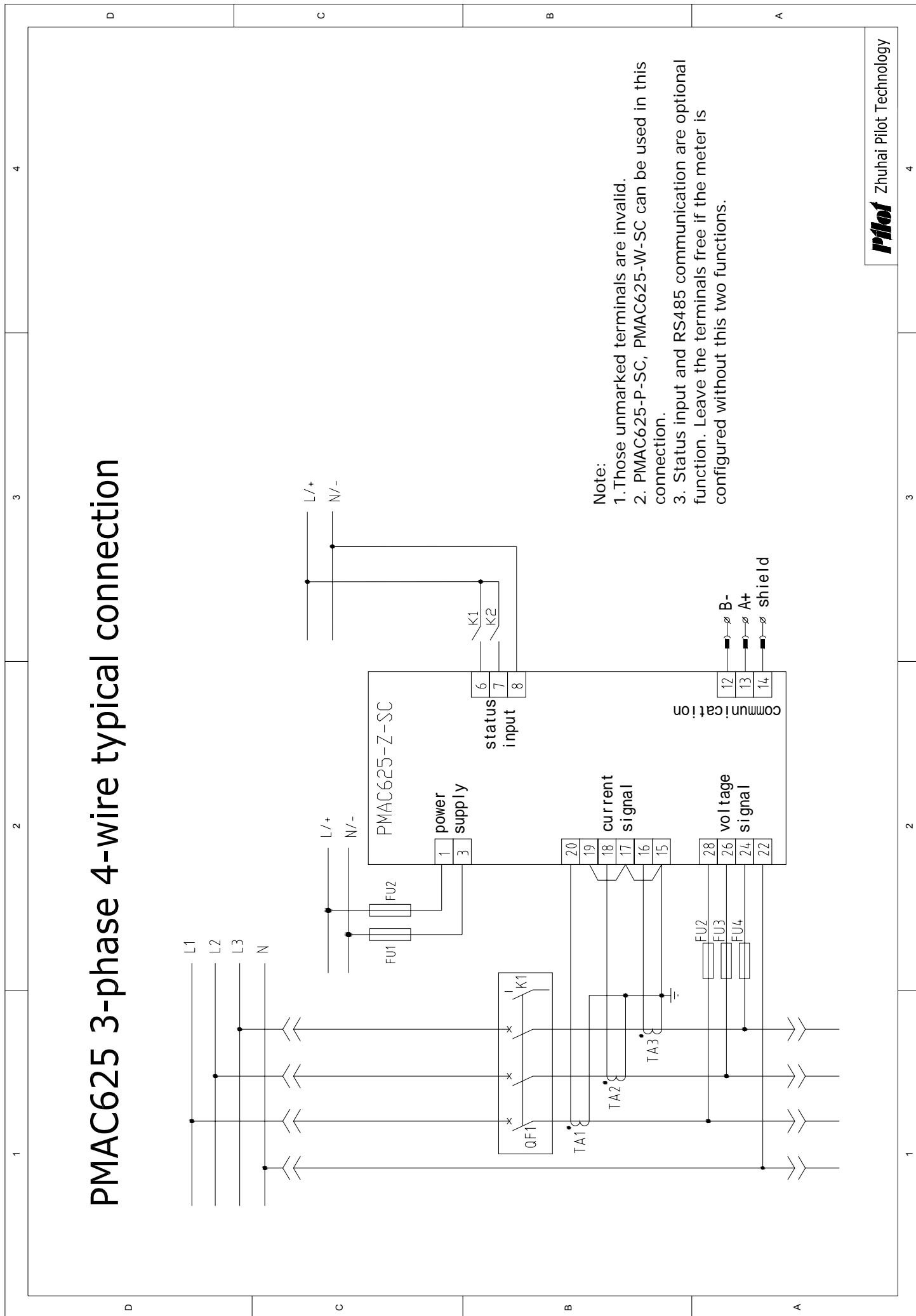

High voltage system, measuring all parameter in 3-phase 3-wire connection mode, with one RS485 communication.

Model: PMAC625H-C

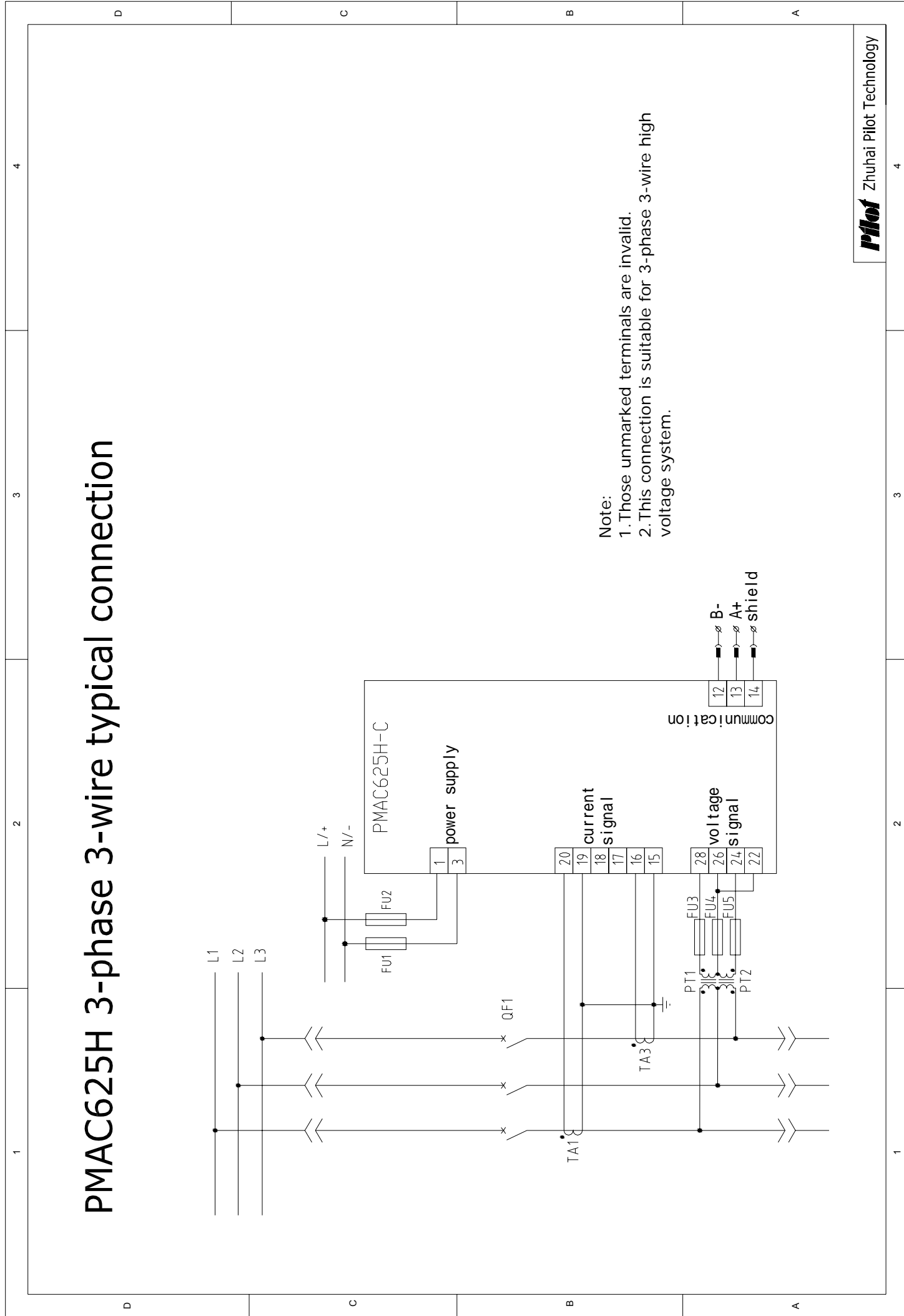

Notice:

- PILOT reserves the right to modify this manual without prior notice in view of continued improvement.
- Technical Consulting: +86 15916202620
- After-sale Services: +86 15916202800
- Email: pilot166@pmac.com.cn

 **Zhuhai Pilot Technology Co., Ltd.**

Add: No. 15, Keji 6 Road, Chuangxin Hai'an, Tangjia High-tech Zone, Zhuhai,
Guangdong, 519085 China

Tel: +86 -756-3629687/ 3629688

Fax: +86-756-3629600/ 3629670

<http://www.pmac.com.cn>